

## TO OPERATE THE KNIFE'S WIRE CUTTER

Place the hole in the blade over the "T" stud on the scabbard's cutter plate. The knife will then act as a scissors style wire cutter. The blade safety stop on the cutter plate will prevent the blade from rotating further when the cutting action is completed.

The knife blade must always have its **FALSE EDGE** facing towards the wire slot.

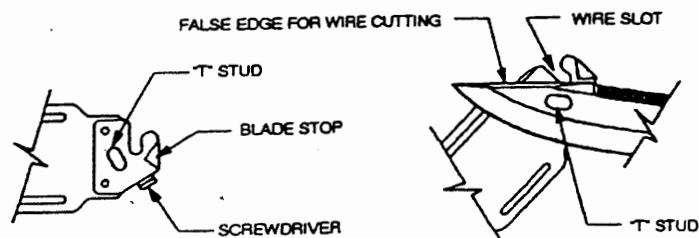

**DO NOT** cut hardened bolts, steel or iron rods or heavy nails with the wire cutter. It is **NOT** designed for this purpose.

## E.O.D. TECHNICIAN

This is your: U.S. E.O.D.

### M11 MULTIPURPOSE KNIFE SYSTEM

It was designed in cooperation with the 52d Ordnance Group (EOD), to serve you as a multipurpose knife, and carrier for your crimpers, pliers and Gerber® tool.

If YOU take care of it and maintain it properly - it will take care of you.

1 September 1998

The Lan-Cay Corporation produces this manual for the U.S. EOD community. We encourage its reproduction for unit training and use.

## M11 NOMENCLATURE

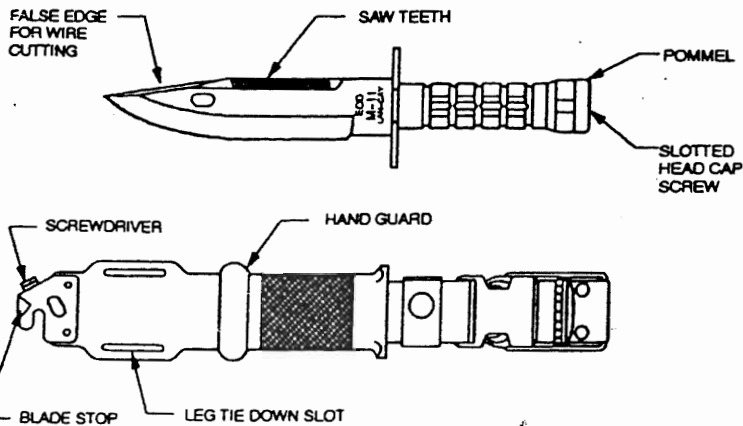

All metal parts of the M11 knife and scabbard should be kept clean and well lubricated. This includes the flat spring inside the scabbard's throat.

## THE M11 TOOL PAC

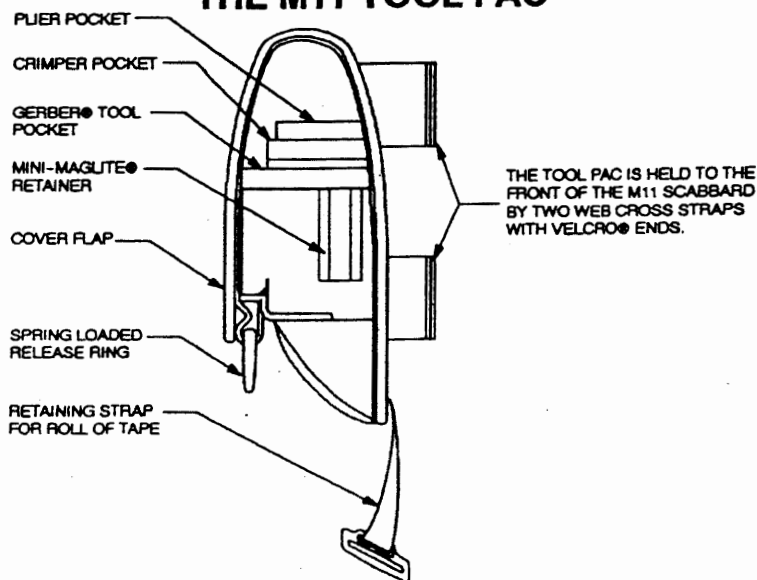

## ⚠ WARNING



### NEVER CUT LIVE ELECTRICAL WIRES

The M11 is **NOT** insulated from electrical current!

The wire cutter is designed for cutting barbed wire and similar materials. **DO NOT** attempt to cut steel bolts or similar hardened materials!



The knife's saw is designed for cutting through wood, plastic and in emergencies, light sheet metal. It is not designed for cutting iron or steel.

The Lan-Cay Corporation  
600 - 4th Street  
Carrollton, KY 41008 U.S.A.

HMB-CRU-HGE

## TO DISASSEMBLE THE POMMEL AND HANDLE FOR CLEANING AND LUBRICATION

Using the screwdriver on the cutter plate (1), unscrew the slotted cap screw (2), remove the pommel (3), and slide off the handle (4). **NO FURTHER DISASSEMBLY IS AUTHORIZED!**

When possible, disassembly should be done in two man teams so that a scabbard remains on the blade of the knife being worked on. This will prevent hand injuries and allow a better grip on the knife being disassembled/reassembled.

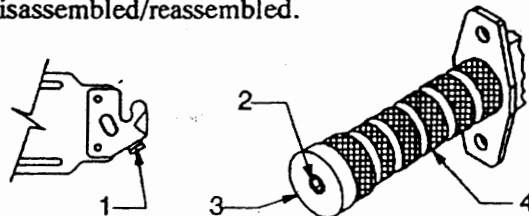

**DURING REASSEMBLY:** the handle **MUST** fit tightly against the handguard and the pommel.

The slotted cap screw **MUST BE PROPERLY TIGHTENED** for the knife's hilt to stay assembled.